



Billet Grinder for Sale

Mfr: Western

Age: 1982

Design: Stationary grinder with moving manipulator car

Billet Size Range: 3" square to 6.125" square - max weight = 3500#, max length 24ft

Grinding Motor: 300HP, 460VAC 60 Hz

Grinding wheel: 24-25" OD x 12" ID x 3-4" width

Wheel speed: 16,500 - 17,180 sfpm

Previous use: Specialty steel producer, very low production rates

Modernization: Complete electrical control replacement 2005 with Allen Bradley PLC based system

Scope of supply

Grinder, Grinder head power unit, grinder lube power unit, grinding wheel changer, manipulator car and drive system with power unit and winch, control cab, swarf collector with 5 bins, charge table, discharge table, controls, hydraulics, grease systems

Grinder is still installed and operable in Northeast USA

Contact Dev Lemster for pricing or to arrange inspection.

over for layout drawing>>>>

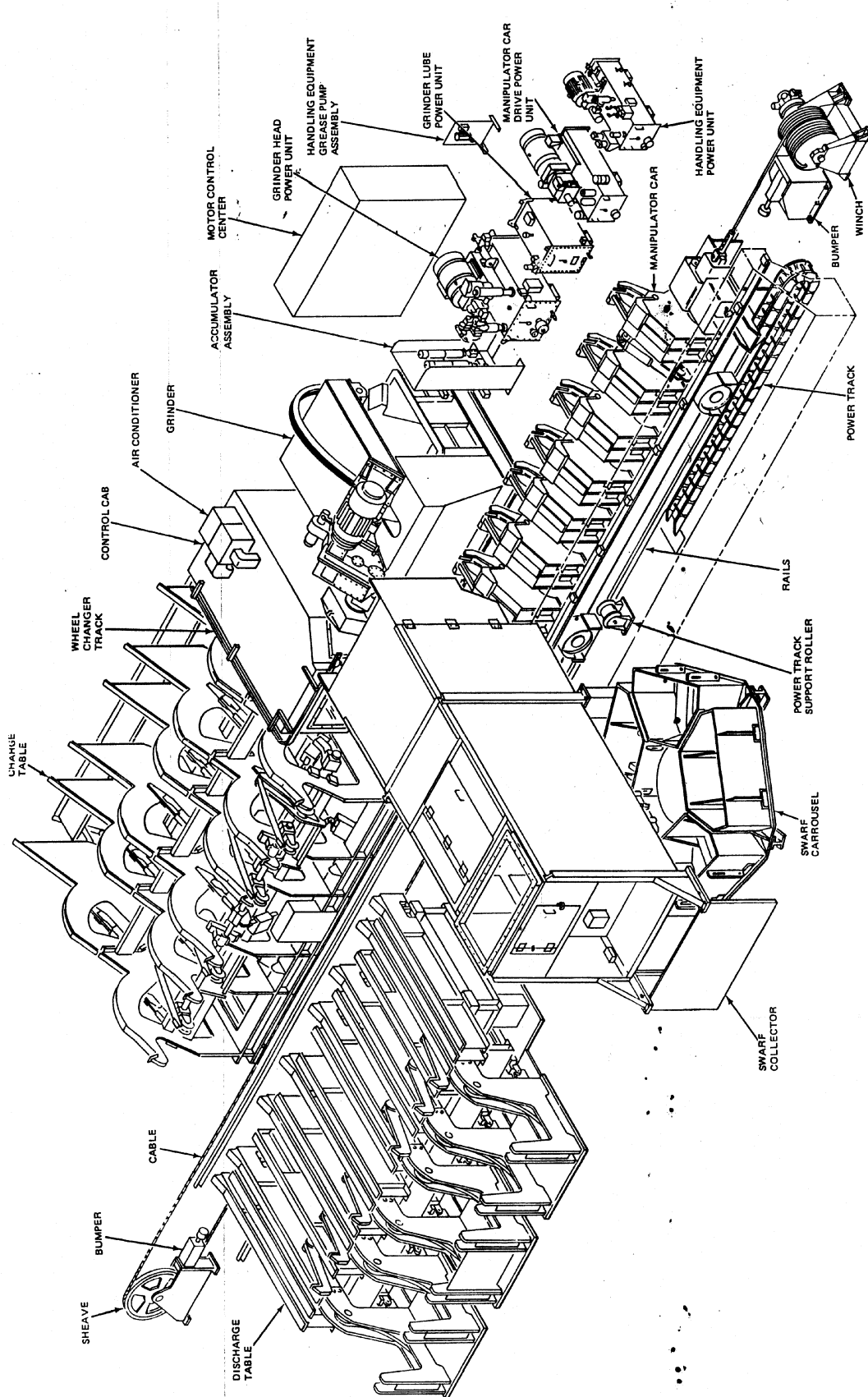

Figure 1-1. Advanced Conditioning Grinder Overall View

1-3/(1-4 blank)